

LSX ENGINE MOUNT PLATES



070001

LSX Engine Mount Adapter Plates

- Allows the installation of LSX style engine with standard SBC motor mounts into popular early model muscle cars.
- CNC Machined from 6061 T6 ALUM and hardcoated for durability
- Includes all heavy duty hardware

Designed to fit the following vehicles with small block frame motor mounts:

67-69 Camaro/Firebird
68-74 Nova
64-72 Chevelle/GTO/Cutlass

Kit includes:

REF#	PART#	DESCRIPTION#	QTY
1	91070001	LSX Engine Mount Plate - Finished RH	1
2	960006	SS FLAT WASHER M10	3
3	980014	SS FHSCS M10-1.5 X 35MM	1
4	980016	SHCS M10-1.5 X 40MM - BLK OXIDE	4
5	980017	FHSCS 3/8"-16 X 1 1/4" - BLK OXIDE	2
6	970006	SS FLANGE NUT 3/8"-16	2
7	91070002	LSX Engine Mount Plate - Finished LH	1



ASSEMBLY OF 070001

INSTALLATION:

SECURE THESE THREE BOLTS TO ENGINE BLOCK FOR EACH MOTOR PLATE. NEXT, LOCATE A SBC MOTOR MOUNT (SOLD SEPARATELY) AND SECURE IT TO THE 3/8" BOLTS ALREADY THREADED INTO THE MOTOR MOUNT PLATE. USE THE REMAINING SHCS TO FASTEN THROUGH THE MOTOR MOUNT AND MOTOR MOUNT PLATE TO THE ENGINE BLOCK.

NOTICE: DO NOT USE BACKING PLATE PROVIDED WITH URETHANE MOTOR MOUNTS.

BOTH PLATES ARE ENGRAVED DRIVER AND PASSENGER SIDES.

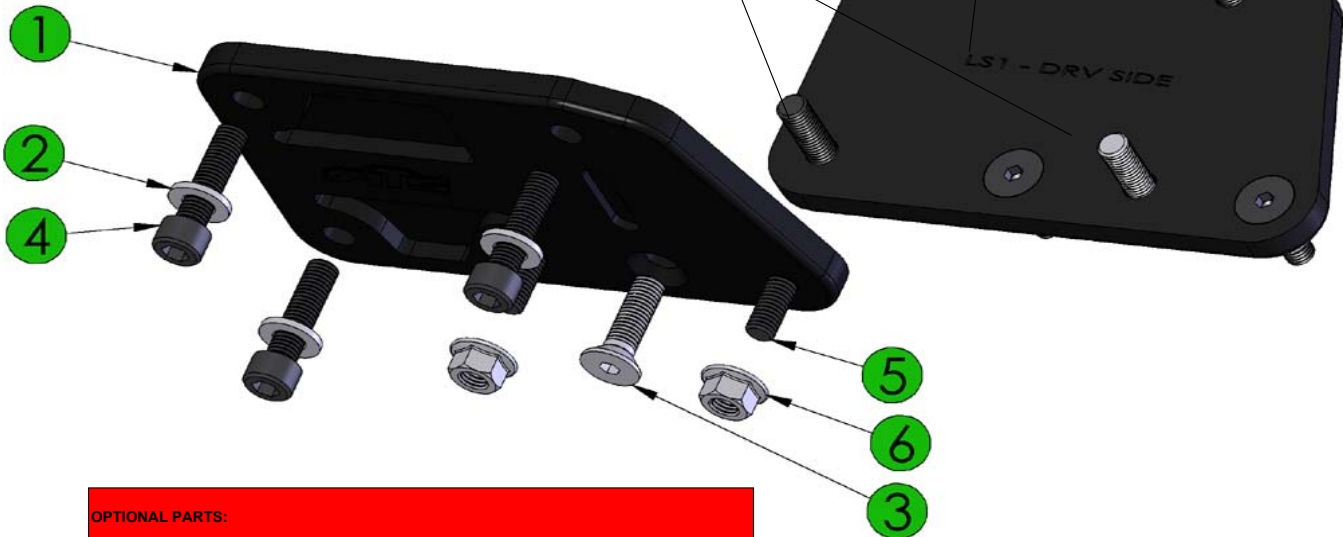

OPTIONAL PARTS:

070002 POLY URETHANE SBC ENGINE MOUNTS ARE SOLD SEPARATELY AND ARE AVAILABLE THROUGH ATS FOR USE IN CONJUNCTION WITH THE ABOVE MOTOR MOUNT ADAPTER PLATES. (SHOWN INSTALLED IN TOP RIGHT PICTURE)