

T56 CROSSMEMBER



080015

T-56 Transmission Crossmember - GEN II F/X Body

- Three piece tubular crossmember
- Constructed from strong chromoly tubing with adjustable stainless receivers
- Powdercoated for long lasting durability and appearance

Designed to fit the following vehicles in conjunction with a late model T56 six speed transmission*:

70-74 CAMARO/FIREBIRD

Kit includes:

REF#	DESCRIPTION#	QTY
1	T56 FRAME MOUNT PLATE - RH	1
2	T56 FRAME MOUNT PLATE - LH	2
3	T56 CROSSMEMBER ASSEMBLY	1
4	STAINLESS RECIEVER DOUBLER PLATE	1
5	STAINLESS ADJUSTABLE RECIEVER	2
6	SOCKET HEAD CAP SCREW 5/16"-24 X 0.75"	4
7	SOCKET HEAD CAP SCREW 5/16"-24 X 1.00"	4

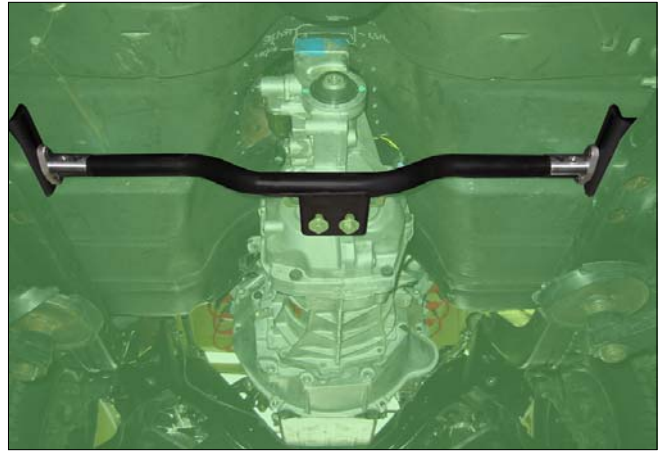

*Customers running a BBC will need to run SBC engine frame mount stands

ASSEMBLY OF 080015

INSTRUCTIONS:

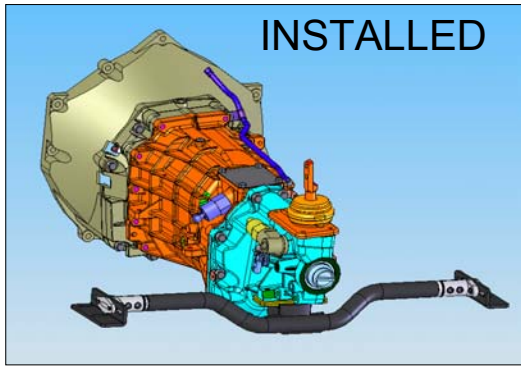

Install T56 transmission with tranny jack up into the floor
 Install both frame mount assemblies with adjustable ends to the frame using factory holes and tightening only hand tight
 Install Turbo 400 transmission mount (not included Energy Suspension PN 3-1108G) to transmission
 Install T56 crossmember tube by adjusting the frame plates crosscar and the adjustable stainless receivers fore aft until the transmission pad holes are lined up on the crossmember and the crossmember is straight.
 Tighten all hardware
 Slowly release the tranny onto the crossmember and secure the tranny pad to the crossmember
 Upon future removal, adjustable receivers may stay secured and the center crossmember dropped

